

PETERBILT 379 1997-2001 ULTRA

VISOR #VP131003

INSTALLATION INSTRUCTIONS

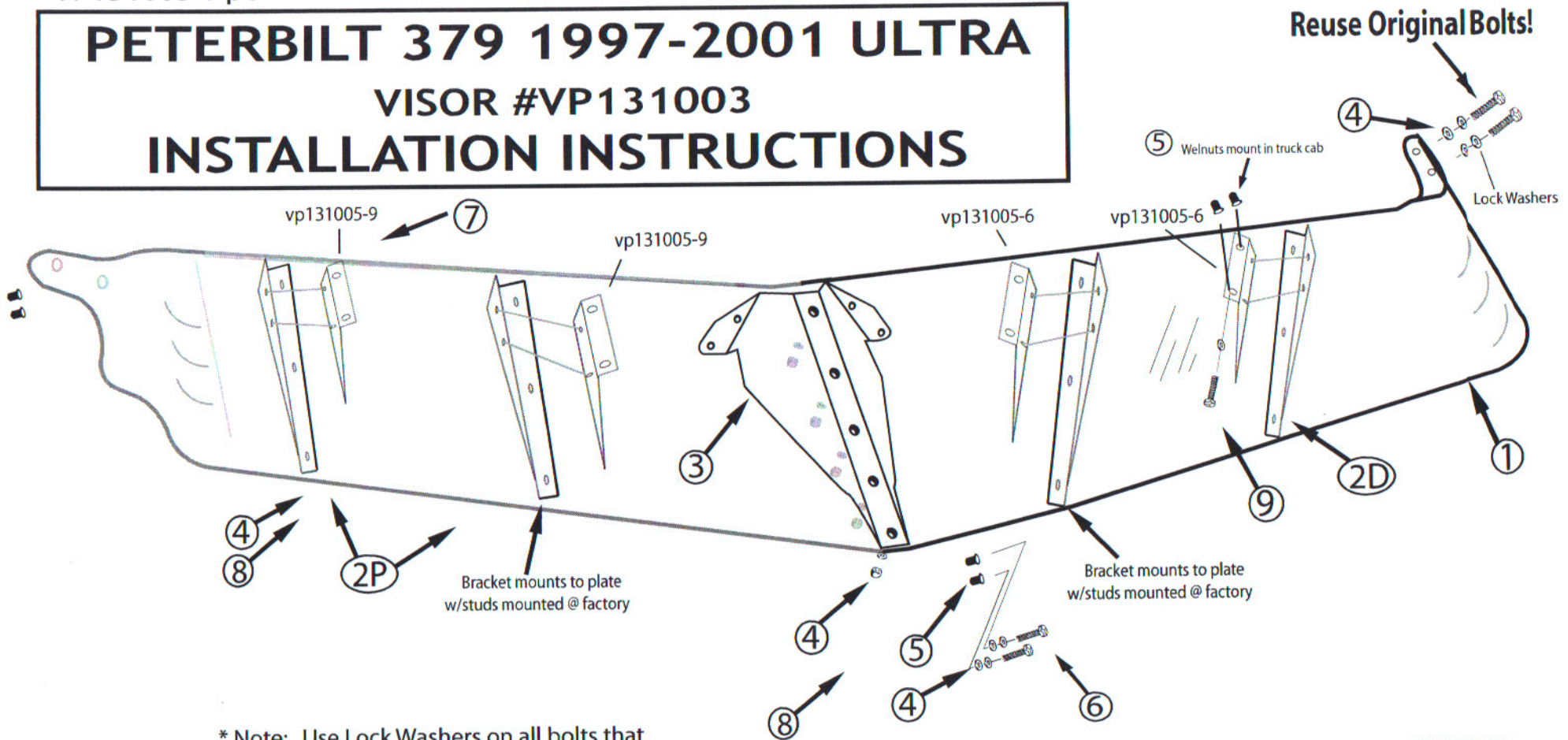

* Note: Use Lock Washers on all bolts that mount directly to truck cab to prevent loosening due to normal road vibrations.

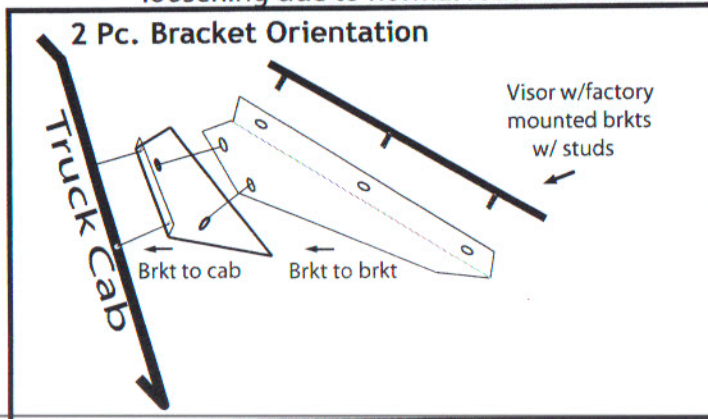

REVISION 5/10

Item	QTY	Description	Size
①	2	Visor body Halve	13.5" x 35"
②D	2	Outer Visor Bracket (vp131005-6)	11-3/4" x 1-7/8"
②P	2	Outer Visor Bracket (vp131005-8)	11-3/4" x 1-7/8"
	2	Outer small Bracket ds (vp131005-6)	
	2	Outer small Bracket ps (vp131005-9)	
③	1	Center Visor Bracket (vp130003-2)	13-1/2" x 7" x 3"
④	50	Washers	1/4-20
*	16	Lock Washers	1/4-20
⑤	12	Rubber Welnuts	1/4-20
⑥	12	Hex Head Bolt	1/4-20x1"
⑦	26	Nylocks	1/4-20
⑧	8	Hex Head Bolt	1/4-20x 3/4"

VP 131003

Peterbilt Ultra-Cab Drop Visor 99-01

1 pc Instructions

Read Entire Instruction Sheet Before Beginning

Safety Glasses	10mm Metric Wrench
Grinder	7/16" Wrench
Silicone or "Loctite [®] "	Phillips Head Screw Driver
Masking Tape	Window Cleaner and Paper Towels
1/2" Drill bit	

Steps:

- 1) Remove your current visor:
 - a) Note: You will need to reuse the bolts which go into the side of the cab at the ends of the visor.
- 2) Grind off the heads of the Huck bolts.
 - a) Hold the existing brackets in place and take your time grinding Huck heads. If you grind too fast or hard it will melt the paint around the head. It is recommended that you only grind a little bit at a time.
- 3) Drill out the "Huck" holes with a 1/2" diameter drill bit.
 - a) Drilling requires you to have a "drill-stop", if you do not have one wrap tape around the drill bit approximately one inch from the tip of the bit, this will prevent "Breaking through" and damaging the interior headliner.
- 4) Press the well nuts into the 1/2" holes. (See Side View illustration)
- 5) Install the mounting bracket per illustration. Once you feel the bolt "bottom out" STOP TIGHTENING.
- 6) Install the visor body.
 - a) Screw in a couple of turns the "side of cab bolts" through the holes in the end of the visor.
 - b) Start the machine screws into the outside bracket to temporarily hold it in position.
- 7) In the center of the visor, screw in the top and bottom machine screws until finger-tight.
- 8) Tighten one of the truss head machine screws in each mounting bracket. Start from the outside of the cab and work toward the middle, one bolt per bracket at a time.
- 9) Remove the PVC coating from the visor.
- 10) Once the visor is in alignment, tighten the machine screws with the Nylock nuts.
- 11) Tighten all remaining bolts and machine screws. We recommend that you use silicone or Loctite[®] on each of the screws to prevent loosening from over the road use.
- 12) Wipe away fingerprints with window cleaner.